

Quantum Mechanical Studies of Environmental Effects on Biomolecules

VII. Hydration of Urea

Yoshimasa Orita* and Alberte Pullman

Institut de Biologie Physico-Chimique, Laboratoire de Biochimie Théorique associé au C.N.R.S., 13, rue P. et M. Curie, F-75005 Paris, France

LCAO SCF calculations with a $(7s, 3p/3s)$ atomic basis are performed on urea and hydrated urea in order to determine the preferred sites of water fixation using the supermolecule approach. It appears that up to five water molecules can be directly bound to urea in the first hydration shell.

Key words: Urea, hydration of ~

1. Introduction

As a continuation of a series of studies on the hydration of fundamental biological molecules [1–9] we are now presenting the hydration scheme of urea.

The physiological role of urea related to the movement of water in the mammalian kidney [10] and the biochemical effect of urea on protein denaturation [11–14] have attracted attention since quite a long time. Although a few quantum-chemical studies have dealt with urea itself [15–23] none has been directed towards these problems. It is hoped that the present work may afford a basis for further studies of the phenomena occurring in the physiology and biochemistry of urea.

2. Standpoint and Method

The geometry and the numbering of the atoms of urea (Fig. 1) were taken from X-ray crystallography [24]. For the water molecule, the experimental values $\text{OH} = 0.957 \text{ \AA}$, $\text{HOH} = 104.5^\circ$, were used.

* *Present address:* Department of Medicine, Osaka University Medical School, Fukushima-Ku, Osaka, 553 Japan.

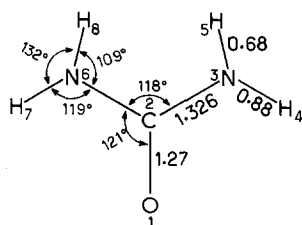

Fig. 1. The crystal structure of urea

As in previous works [1–9], we have adopted the supermolecule approach for the determination of the hydration scheme. In order to facilitate the search for the preferred paths of approach of the water molecule. We have first calculated the electrostatic molecular potential of urea.

Interaction of urea with one water molecule (monohydrate) was considered then so as to determine the preferred sites of attachment. Then, the successive addition of further water molecules was considered in the same way (including reoptimization at each step), until completion of the first hydration shell.

The computations were carried out *ab initio* by the SCF LCAO procedure with a (7s, 3p/3s) atomic Gaussian basis contracted to a minimal basis set [26], the same as in the case of formamide [1].

It must be noted that like most minimal basis sets, the present one yields a somewhat overestimated hydrogen bond energy (-6.6 kcal/mole for the water dimer [27]). However, this does not impair the significance of our results as was discussed before [9].

3. Results and Discussion

3.1. Structure and Molecular Potential of Urea

The result of a Mulliken population analysis is shown in Fig. 2 where the results are compared with the corresponding ones for formamide [28].

Urea shows a stronger opposition of the net charges (both π and σ) than formamide.

The π net charge of the nitrogen is not too different from the result of the simple HMO method (+185) but the π net charges of the oxygen and the carbon were overestimated by the simple HMO method (-120 for the oxygen, $+349$ for the carbon) [15].

As expected, the delocalization of the π lone pair of each nitrogen in urea is smaller than that of the π lone pair in formamide but the total π donation is increased with respect to formamide.

Another aspect of the molecular structure is given by the molecular potential. Fig. 3a gives the isopotential map in the molecular plane. Fig. 3b gives the isopotential map in the perpendicular section containing a C–N bond. Fig. 3c gives the isopotential map in a plane parallel to the first one at 2.5 a.u. The most strongly

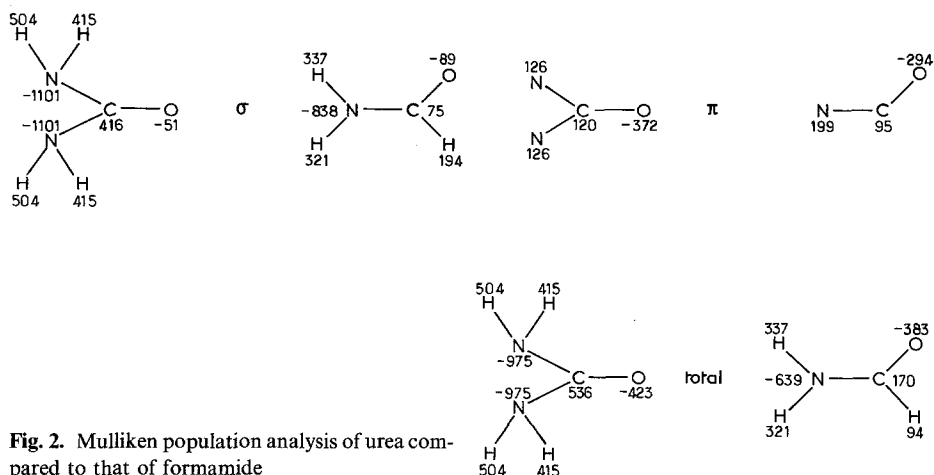

Fig. 2. Mulliken population analysis of urea compared to that of formamide

attractive region is that of the carbonyl oxygen with two potential minima situated in the molecular plane symmetrically in the directions making the angle of $\pm 20^\circ$ with the C–O bond. It is observed that the value of the potential minimum and its geometry (-68.5 kcal, 20°) are very close to those of formamide (-67.1 kcal, 19°) [29]. The rest of the in-plane approach of urea appears repulsive, as in formamide.

The map in the perpendicular plane containing a C–N bond indicates small attractive regions extending above (and symmetrically below) the molecular plane, as seen still better on Fig. 3c.

The potential minimum (-20 kcal) which was observed along the extension of the C–N bond of formamide disappears in the case of urea. Urea has a new minimum (-8.4 kcal) above the prolongation of the C–N bond. The minimum of molecular potential and the geometry above (and below) the nitrogen atom are almost the same as those of formamide.

On the whole, from the electrostatic point of view, the proton affinity of urea should favor oxygen over nitrogen protonation, as was the case in formamide [29]. CNDO approximate potentials lead to the same conclusion [22]. It is possible that the polarization, charge transfer, and deformation effects [30] bring the two protonation energies closer together. Since the object of the present study is hydration, we do not pursue here the subject of protonation itself concerning which the experimental information is scarce and rather inconclusive [31–33].

3.2. Monohydrates of Urea

The position of the water molecule with respect to urea is defined in the following way (Fig. 4): the location of the oxygen atom of water O_w is defined by polar

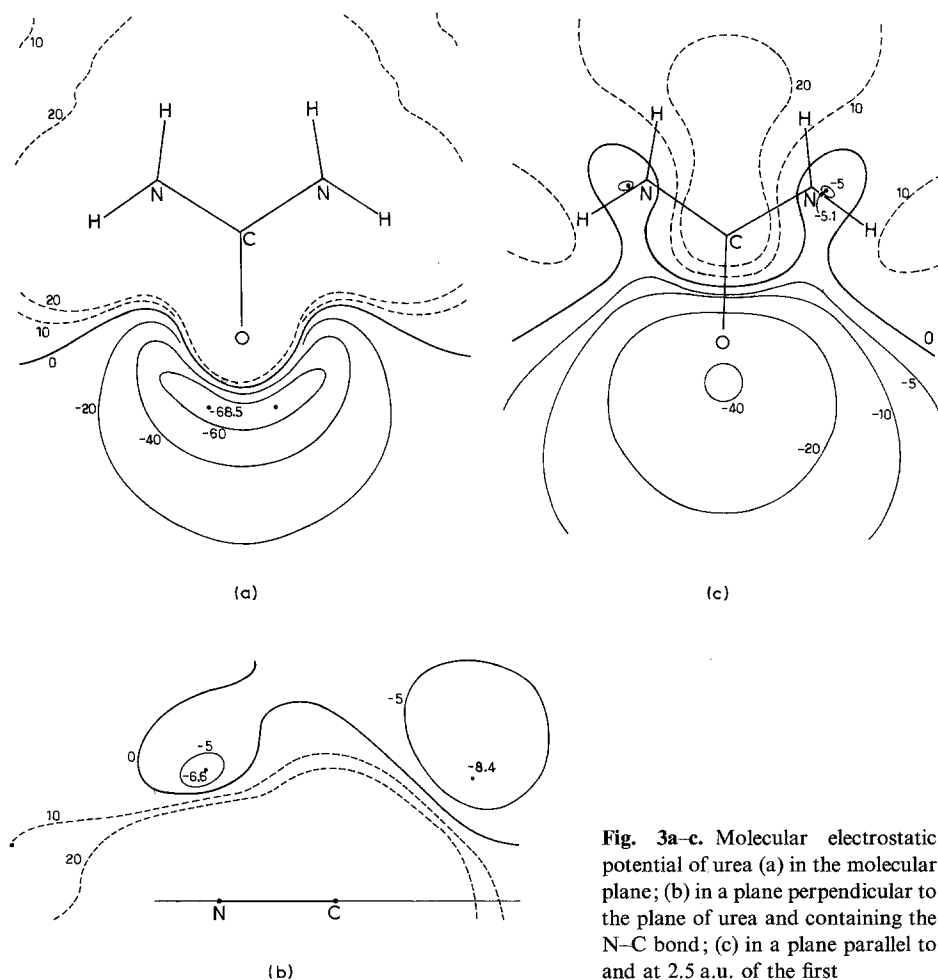

Fig. 3a-c. Molecular electrostatic potential of urea (a) in the molecular plane; (b) in a plane perpendicular to the plane of urea and containing the N-C bond; (c) in a plane parallel to and at 2.5 a.u. of the first

coordinates centered on the atom (N or O) of urea to which the water is bound, the polar axis being, according to the case, either the CO axis or the NH direction. θ is the polar angle counted from the polar axis, R the distance OO_w or NO_w . When the oxygen of water is in the plane of urea, the azimuthal angle φ is zero or 180° as indicated in Fig. 4.

Moreover, the orientation of the water molecule is defined with respect to three *local* axes centered on the water oxygen and such that η is always directed along the O_wO or O_wN direction, ξ perpendicular to it in the plane of urea, and ζ forming with them a direct trihedron (thus perpendicular to the urea plane). For site I, the orientation $\xi = \eta = \zeta = 0$ is shown on Fig. 4. For sites II and III the orientation $\xi = \eta = \zeta = 0$ corresponds to water perpendicular to the plane of urea and bisected by the NO_w direction. ξ , η , ζ define the rotations about the corresponding axes from these zero positions.

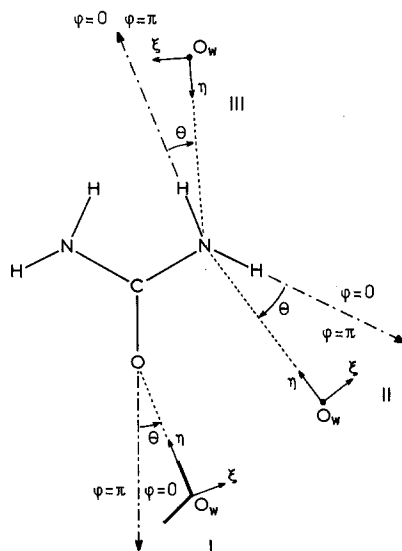

Fig. 4. Definition of angles in the three kinds of sites. Polar axis (—); H bond axis (·····)

Table 1. Geometries and stabilization energies of the three most stable monohydrates of urea

	R^a (Å)	φ (degree)	θ (degree)	η (degree)	ξ (degree)	ζ (degree)	ΔE kcal/M
I	2.80	0	75.0	0	0	0	-10.2
II	2.80	0	0	0	0	-60.0	-7.4
III	2.80	0	11.8	0	0	-23.3	-8.4

^a In all the sites the bottom of the energy-distance curve was very flat (see Fig. 5 for examples).

Table 1 gives the characteristics of the most stable positions of one water molecule. Fig. 5 shows some of its lability [9] characteristics.

3.2.1. The Carbonyl Region

The most stable region (I) occurs at two symmetrical positions: for $\theta = 75^\circ$, $\varphi = 0^\circ$ and $\varphi = 180^\circ$, $R = 2.8 \text{ \AA}$. These positions are very similar to the positions I and II of formamide [1] ($\theta = 88^\circ$ and 72° respectively, $R = 2.815 \text{ \AA}$). The stabilization energy of the monohydrate of urea in this preferred position (-10.2 kcal/M) is greater than that of the best monohydrates of formamide computed with the same basis set (-9.2 and -9.0 kcal/M for a linear H bond [1]). The same result obtains in the STO 3G

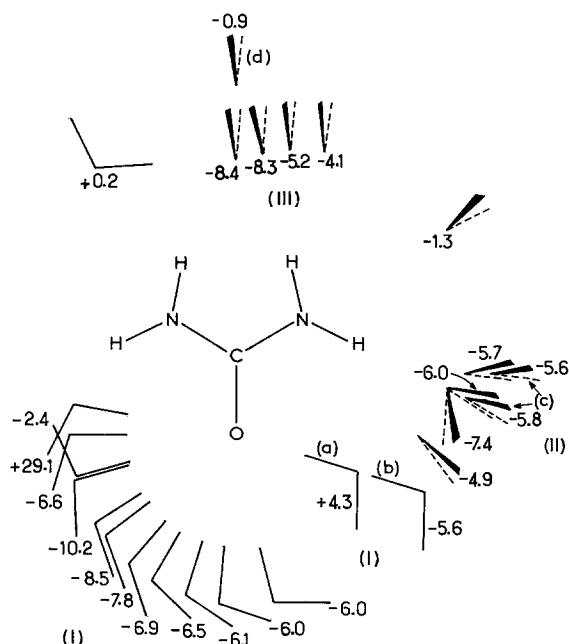

Fig. 5. In-plane monohydration of urea. (a) $R=2.10$ Å; (b) $R=3.30$ Å; (c) $R=2.85$ Å; (d) $R=5.5$ Å; in all other positions $R=2.80$ Å

basis [19]. We did not perform here the calculation of the in-plane rotation (ζ) which could demonstrate a non-linearity of the hydrogen bond, because the increase of the stabilization energy by this rotation was only a few tenths of a kcal/M in the case of formamide, and the departure from linearity very small.¹

Note that, like in formamide, the direction of the hydrogen bond corresponds to an angle θ larger than that corresponding to the potential minimum, due to the fact that the charge transfer component of the binding energy is maximum in the direction perpendicular to the C—O axis (where the most labile lone-pair orbital of the oxygen atom has its maximum density) [30].

The lability characteristics of the monohydrates on the carbonyl oxygen follow a pattern similar in many respects to those of the formamide hydrates. Note, in particular, the relatively large “*ad situm*” lability particularly on the side of the C—O axis. The axis position is a little more favorable here than in formamide.

3.2.2. The Amino Groups

In the region of the NH_2 groups, there are two well-defined hydration zones: one involving the NH bond-*cis* to the carbonyl bond (II), the other involving the *trans*-NH bond (III). At a nitrogen-oxygen distance of 2.8 Å the most stable *cis*-NH bond

¹ Here the situation differs from the STO 3G results, where the most stable hydrate corresponds to one water molecule bound simultaneously to NH and CO in a “cyclic” structure. This is most likely an artifact of the STO 3G basis which allows very short equilibrium distances permitting such a configuration, which is not favorable with the more reasonable distances of the present basis set.

(II) occurs at $\theta = 0$, $\zeta = -60^\circ$ (Fig. 5). In this configuration, instead of being bisected by the NH axis, the water molecule turns its hydrogens 60° towards the oxygen atom so as to feel at best its attraction. The maximum stabilization energy calculated (-7.4 kcal/M) is somewhat smaller than that found in the corresponding region of formamide. The lability characteristics of Fig. 5 speak for themselves.

The most stable binding to the trans NH bond occurs at $\theta = -10.8^\circ$, $\zeta = -23.8^\circ$ (the water molecule bisecting the extended line of the C–O bond). The value obtained of -8.4 kcal/M is larger than the binding energy of region IV in formamide, due to the attraction by both NH bonds. This bisecting position is more stable by 0.1 kcal than direct binding to either trans NH bond. The *in situ* lability in these regions is relatively small because any rotation of the water molecule causes a repulsive interaction with the next NH₂ group. The non-linearity of the hydrogen bond is obvious in this region but the difference of energy is very small. The loss of binding energy by *extra situm* movement occurs relatively fast.

Apart from this rather detailed exploration in the plane of urea, we tested the possibility of existence of stable out-of-plane sites of hydration. For a distance $O_wN = 3.35$ Å with one OH pointing perpendicularly above one N atom, with the second hydrogen turned towards the second nitrogen in the NO_wN plane, the binding energy was -1.1 kcal/mole (less than in formamide). Another position (O_w at 3.35 Å above the bisectrix of NCN) is still less favorable. Clearly, out-of-plane monohydration is unfavored as found in similar cases [1, 4].

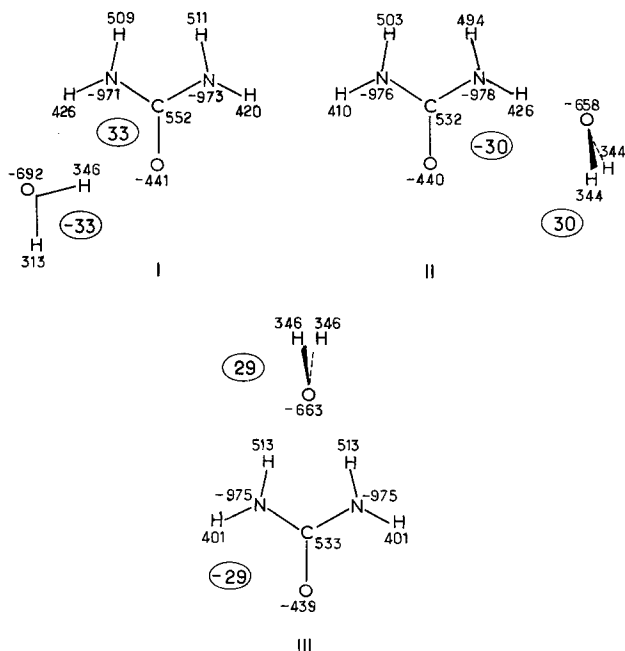

Fig. 6. Mulliken populations in three monohydrates of urea ($10^{-3}e$ unit). The circled number is the global charge transfer. (The net charges in isolated water are $+326$ on H, -652 on O.)

Fig. 6 gives the net charges of the monohydrates of urea in the three preferred positions, as well as the global charge transfer to H_2O (I) or from it (II, III).

3.3. Polyhydration

It is clearly not possible to occupy simultaneously the best positions I and II on the same side, but like in formamide [34], the lability characteristics permit to foresee that a small displacement of each water molecule, will allow the formation of a dihydrate, in which the two water molecules are bound to each other in a structure very close to that of a water dimer [35]. Indeed, this is the situation obtained by optimization (Fig. 7a) where the total binding energy is -19.2 kcal/M (the accuracy

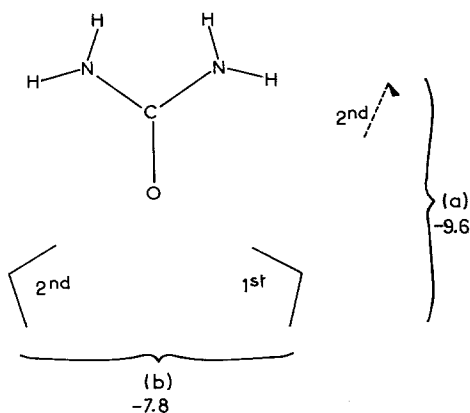

Fig. 7. Geometries and stabilization energies per water molecule for two dihydrates of urea (see text)

of the value is not quite as good as for the monohydrate since the optimization was not pushed as far, due to the computational cost). In order to explore whether a symmetrical positioning of two such couples of water molecules (one on each side of the C–O axis) was possible, we tested the configuration of Fig. 6b with only two water molecules in the appropriate symmetrical positions: it is seen that this arrangement does not give rise to too strong a repulsion since the total stabilization energy is -15.6 kcal/M. Table 2 gives the characteristics of the positions and Fig. 8 gives the charge distribution in the two dihydrates (a) and (b).

We then proceeded to include more water molecules around urea, utilizing the four positions so far obtained. It is obvious from the results on monohydration that direct binding of water to urea in the first shell is unlikely inside the HNH angle of

Table 2. Geometries and stabilization energies of dihydrates of urea

	First water molecule						Second water molecule						$\Delta E/2$
	R	φ	θ	η	ξ	ζ	R	φ	θ	η	ξ	ζ	
<i>a</i>	2.80	0	60	0	0	0	2.80	0	10	0	75	-100	-9.6
<i>b</i>	2.80	0	60	0	0	0	2.80	0	60	0	0	0	-7.8

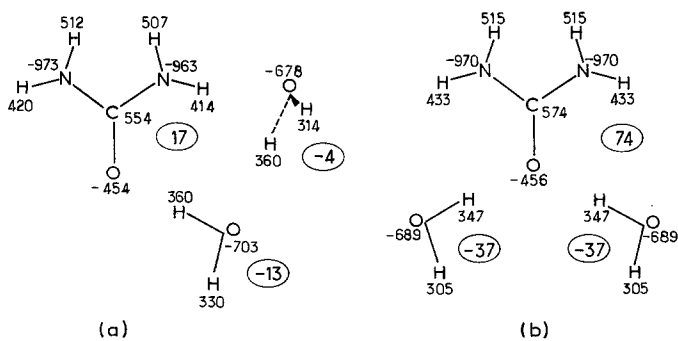

Fig. 8. Mulliken population in the dihydrates of Fig. 7 (Notation is the same as that of Fig. 7)

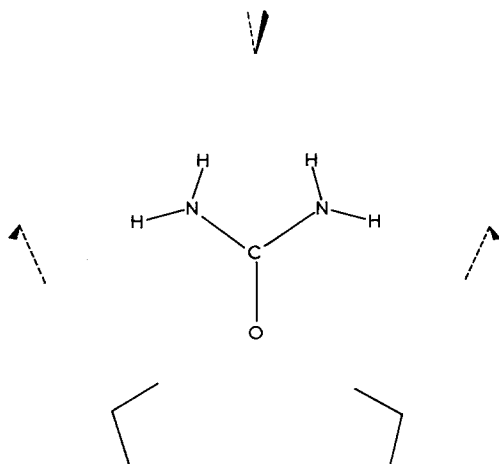

Fig. 9. The first hydration layer around urea (the distances have not been reoptimized)

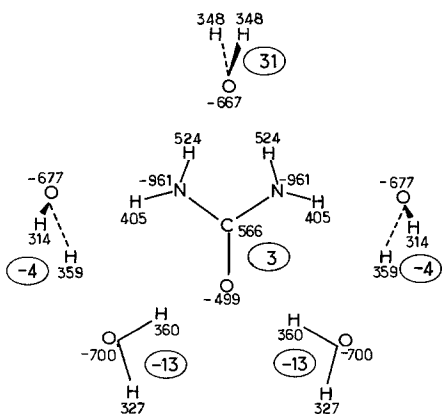

Fig. 10. Mulliken population in the pentahydrate of urea (Notation is the same as that of Fig. 7)

the NH_2 group. In fact, the sole possibility is binding in position III. The structure of the pentahydrate is given in Fig. 9. Its average binding energy per water molecule is -7.4 kcal/M.

The charge distribution in the pentahydrate is given on Fig. 10. The comparison with the isolated molecule and with the mono and dihydrates is interesting: in the completely hydrated molecule, the global loss of electrons from urea is practically negligible, a compensation obviously occurring between the losses and gains due to the various positions. Moreover, the electrons gained from the water in position III are practically the same as in the corresponding monohydrate and compensate for the loss to the water dimers on each side of the carbonyl group.

It is of course important to realize that the absence of global charge transfer to or from the central molecule does not mean that it is not polarized: in fact, an appreciable polarization appears when comparing the individual atoms in Figs. 10, 8 and 3.

4. Conclusion

On the whole, urea hydration seems somewhat easier than that of formamide, both due to the intrinsic better proton-acceptor ability of the carbonyl group of urea, and to the existence of symmetrical positions of the minima on the hypersurface of interaction. The first solvation shell can accommodate five water molecules directly bound to the solvated urea whereas a maximum of four molecules of water seem to be able to bind directly to formamide [34], where the fifth water molecule prefers to remain in the second shell [36].

The binding energies found for the urea-water adducts are all larger than the corresponding energies for water-water interactions, a situation which indicates the capability of urea to disrupt the structure of water [37], and which is in agreement with the observations made on the effect of urea on the functioning of the mammalian kidney [10].

Acknowledgements. One of us (Y. Orita) wishes to thank the C.I.E.S. of the French Government and the authorities of the French Embassy in Japan, in particular Prof. M. Dupuis, for a support permitting the completion of this work.

References

1. Alagona, G., Pullman, A., Scrocco, E., Tomasi, J.: *Intern. J. Peptide Protein Res.* **5**, 251 (1973)
2. Pullman, A., Alagona, G., Tomasi, J.: *Theoret. Chim. Acta (Berl.)* **33**, 87 (1974)
3. Pullman, A., Armbruster, A-M.: *Intern. J. Quantum Chem.; Quant. Biol. Symp.* **1**, 21 (1974)
4. Port, G. N. J., Pullman, A.: *Intern. J. Quantum Chem.* **S8**, 169 (1974)
5. Perahia, D., Pullman, A., Berthod, H.: *Theoret. Chim. Acta (Berl.)* **40**, 47 (1975)
6. Pullman, A., Berthod, H., Gresh, N.: *Chem. Phys. Letters* **33**, 11 (1975)
7. Pullman, B., Pullman, A., Berthod, H., Gresh, N.: *Theoret. Chim. Acta (Berl.)* **40**, 93 (1975)
8. Pullman, B., in: *Environmental effects on molecular structure and properties*, p. 55. B. Pullman ed. Dordrecht, Holland: Reidel 1976

9. Pullman, A., in: Proceedings of 2nd Intern. Congr. Quantum Chem., p. 149. B. Pullman and R. Parr eds. Dordrecht, Holland: Reidel 1976
10. Schmidt-Nielsen, B. (ed.): Urea and the kidney, Excerpta Med. (1970)
11. Reithel, F. J.: Advan. Protein Chem. **18**, 123 (1963)
12. Tanford, C.: Advan. Protein Chem. **23**, 122 (1968)
13. Tanford, C.: Advan. Protein Chem. **24**, 2 (1970)
14. Edelhoich, H., Osborne, J. C.: Advan. Protein Chem. **30**, 183 (1976)
15. Orita, Y., Urakabe, S., Furukawa, T., Abe, H.: Jap. Circul. J. **30**, 1185 (1966)
16. Ditchfield, R., Del Bene, J. E., Pople, J. A.: J. Am. Chem. Soc. **94**, 703 (1972)
17. Middlemiss, K. M., Santry, D. P.: Chem. Phys. Letters **28**, 140 (1974)
18. Elbert, S. T., Davidson, E. R.: Intern. J. Quantum Chem. **8**, 857 (1974)
19. Del Bene, J. E.: J. Chem. Phys. **63**, 4666 (1975)
20. Del Bene, J. E., Vaccaro, A.: J. Am. Chem. Soc. **98**, 7526 (1976)
21. Dougherty, D., Wittel, K., Meeks, J., McGlynn, S. P.: J. Am. Chem. Soc. **98**, 3815 (1976)
22. Patelev, Yu. A., Lipovskii, A. A.: Zh. Strkturnoi Khimit (Eng. Transl.) **17**, 2 (1976)
23. Patelev, Yu. A., Lipovskii, A. A.: Zh. Strkturnoi Khimit (Eng. Transl.) **17**, 9 (1976)
24. Caron, A.: Acta Cryst. **B25**, 404 (1969)
25. Bonaccorsi, R., Scrocco, E., Tomasi, J.: J. Chem. Phys. **52**, 5270 (1970)
26. Clementi, E., Andre, J. M., Klint, D., Hahn, M. D.: Acta Phys. Acad. Sci. Hung. **27**, 4931 (1969)
27. Pullman, A., Berthod, H., unpublished data
28. Dreyfus, M., Maigret, B., Pullman, A.: Theoret. Chim. Acta (Berl.) **17**, 109 (1970)
29. Bonaccorsi, R., Pullman, A., Scrocco, E., Tomasi, J.: Chem. Phys. Letters **12**, 622 (1972)
30. Dreyfus, M., Pullman, A.: Theoret. Chim. Acta (Berl.) **19**, 20 (1970)
31. Olah, G. A., White, A. M.: J. Am. Chem. Soc. **90**, 6087 (1968)
32. Vold, R. L., Daniel, E. S., Chan, S. O.: J. Am. Chem. Soc. **92**, 6771 (1970)
33. Congdon, W. I., Edward, J. T.: J. Am. Chem. Soc. **94**, 6096 (1972)
34. Hinton, J. F., Harpool, R. D.: J. Am. Chem. Soc. **99**, 349 (1977)
35. Pullman, A.: Bull. Soc. Chim. Belg. **85**, 963 (1976)
36. Pullman, A., Berthod, H., Giessner-Prettre, C., Hinton, J.: to be published
37. Frank, H. S., Franks, F.: J. Chem. Phys. **48**, 4746 (1968)

Received March 28, 1977